

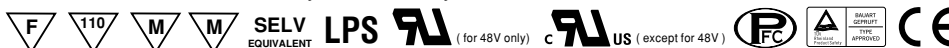

■ Features :

- Universal AC input / Full range
- Fully isolated plastic case with terminal block style of I/O
- Built-in constant current limiting circuit
- Adjustable output voltage and current level
- Protections: Short circuit/Over load/Over voltage/Over temperature
- Built-in active PFC function, comply with EN61000-3-2 class C ($\geq 75\%$ load)
- UL1310 class 2 power unit
- Pass LPS
- Cooling by free air convection
- 100% full load burn-in test
- High reliability
- Suitable for LED lighting and moving sign applications
- Compliance to worldwide safety regulations for lighting
- 2 years warranty



SPECIFICATION

MODEL		PLC-45-12	PLC-45-15	PLC-45-20	PLC-45-24	PLC-45-27	PLC-45-36	PLC-45-48
OUTPUT	DC VOLTAGE	12V	15V	20V	24V	27V	36V	48V
	CONSTANT CURRENT REGION Note.6	9 ~ 12V	11.25 ~ 15V	15 ~ 20V	18 ~ 24V	20.25 ~ 27V	27 ~ 36V	36 ~ 48V
	RATED CURRENT	3.8A	3A	2.3A	1.9A	1.7A	1.25A	0.95A
	CURRENT RANGE	0 ~ 3.8A	0 ~ 3A	0 ~ 2.3A	0 ~ 1.9A	0 ~ 1.7A	0 ~ 1.25A	0 ~ 0.95A
	RATED POWER	45.6W	45W	46W	45.6W	45.9W	45W	45.6W
	RIPPLE & NOISE (max.) Note.2	2Vp-p	2.4Vp-p	1.8Vp-p	2.7Vp-p	2.7Vp-p	3.6Vp-p	4.6Vp-p
	VOLTAGE ADJ. RANGE Note.5	11.5 ~ 13V	14.5 ~ 16.2V	19.5 ~ 22V	24 ~ 26V	25 ~ 30V	32.5 ~ 39V	43.6 ~ 51.8V
	CURRENT ADJ. RANGE Note.5	2.85 ~ 3.914A	2.25 ~ 3.1A	1.725 ~ 2.37A	1.425 ~ 1.957A	1.275 ~ 1.75A	0.938 ~ 1.288A	0.713 ~ 0.979A
	VOLTAGE TOLERANCE Note.3	$\pm 10\%$						
	LINE REGULATION	$\pm 3.0\%$						
LOAD REGULATION	$\pm 5.0\%$							
SETUP TIME	1500ms / 230VAC 3000ms / 115VAC at full load							
INPUT	VOLTAGE RANGE Note.4	90 ~ 264VAC 127 ~ 370VDC						
	FREQUENCY RANGE	47 ~ 63Hz						
	POWER FACTOR	PF ≥ 0.9 at 75 ~ 100% load, 115VAC / 230VAC						
	EFFICIENCY(Typ.)	83.5%	85%	86.5%	86.5%	86.5%	87.5%	87.5%
	AC CURRENT	0.55A/115VAC 0.25A/230VAC						
	INRUSH CURRENT(max.)	40A/230VAC						
LEAKAGE CURRENT	<0.75mA / 240VAC							
PROTECTION	OVER CURRENT	95 ~ 110%	110% (max)					
	SHORT CIRCUIT	Hiccup mode, recovers automatically after fault condition is removed.						
	OVER VOLTAGE	13.8 ~ 16V	17.5 ~ 21V	22.8 ~ 25V	28 ~ 32V	31 ~ 35V	41 ~ 46V	54 ~ 60V
	OVER TEMPERATURE	95°C $\pm 10^\circ\text{C}$ (TSW1) detect on heatsink of power transistor Protection type : Shut down o/p voltage, recovers automatically after temperature goes down						
ENVIRONMENT	WORKING TEMP.	-30 ~ +50°C (Refer to output load derating curve)						
	WORKING HUMIDITY	20 ~ 95% RH non-condensing						
	STORAGE TEMP., HUMIDITY	-40 ~ +80°C, 10 ~ 95% RH						
	TEMP. COEFFICIENT	$\pm 0.03\%/^\circ\text{C}$ (0 ~ 50°C)						
	VIBRATION	10 ~ 500Hz, 2G 12min./1cycle, period for 72min. each along X, Y, Z axes						
SAFETY & EMC	SAFETY STANDARDS	UL1310 Class 2, TUV EN61347-1, EN61347-2-13, CAN/CSA C22.2 No. 223-M91(except for 48V) approved						
	WITHSTAND VOLTAGE	I/P-O/P:3.75KVAC I/P-FG:1.88KVAC O/P-FG:0.5KVAC						
	ISOLATION RESISTANCE	I/P-O/P:100M Ohms / 500VDC / 25°C / 70% RH						
	EMI CONDUCTION & RADIATION	Compliance to EN55015, EN55022 (CISPR22) Class B						
	HARMONIC CURRENT	Compliance to EN61000-3-2 Class C ($\geq 75\%$ load) ; EN61000-3-3						
OTHERS	EMS IMMUNITY	Compliance to EN61000-4-2,3,4,5,6,8,11; ENV50204, EN55024, EN61547, light industry level, criteria A						
	MTBF	515Khrs min. MIL-HDBK-217F (25°C)						
	DIMENSION	181.5*62*35mm (L*W*H)						
	PACKING	0.41Kg; 30pcs/13.3Kg/0.67CUFT						
NOTE	<ol style="list-style-type: none"> 1. All parameters NOT specially mentioned are measured at 230VAC input, rated load and 25°C of ambient temperature. 2. Ripple & noise are measured at 20MHz of bandwidth by using a 12" twisted pair-wire terminated with a 0.1uF & 47uF parallel capacitor. Direct connecting to LEDs is not suggested for models with "RIPPLE & NOISE" $> \pm 10\%$ and using additional drivers is highly recommended. 3. Tolerance : includes set up tolerance, line regulation and load regulation. 4. Derating may be needed under low input voltage. Please check the static characteristics for more details. 5. Output voltage can be adjusted through the SVR1 on the PCB ; limit of output constant current level can be adjusted through the SVR2 on the PCB. 6. Constant current operation region is within 75% ~ 100% rated output voltage. This is the suitable operation region for LED related applications, but please reconfirm special electrical requirements for some specific system design. 7. The power supply is considered as a component that will be operated in combination with final equipment. Since EMC performance will be affected by the complete installation, the final equipment manufacturers must re-quality EMC Directive on the complete installation again. 							

■ Mechanical Specification

Case No.991A Unit:mm

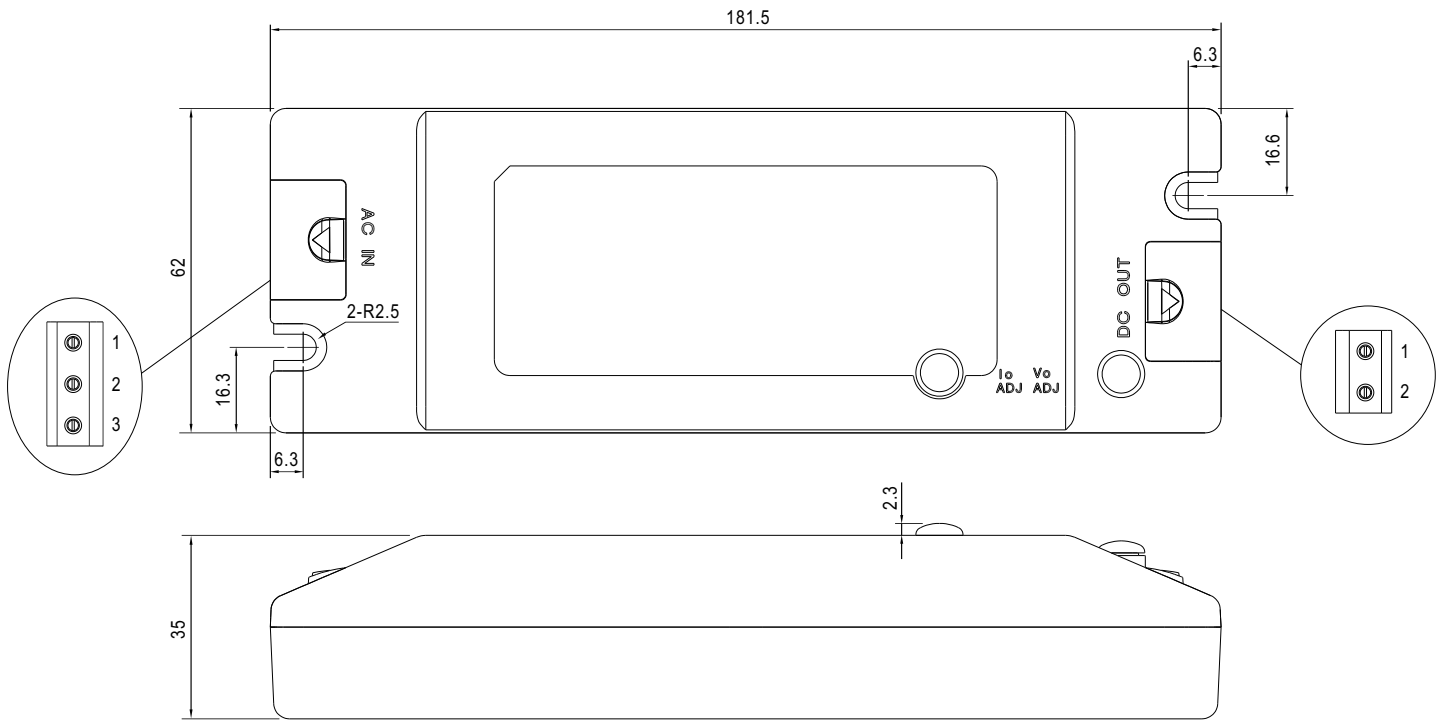

Terminal Pin No. Assignment (TB1):
SWITCLAB MB310-75003

Pin No.	Assignment
1	AC/L
2	AC/N
3	FG ⊕

Terminal Pin No. Assignment (TB2):
SWITCLAB MB310-75002

Pin No.	Assignment
1	+V
2	-V

■ Block Diagram

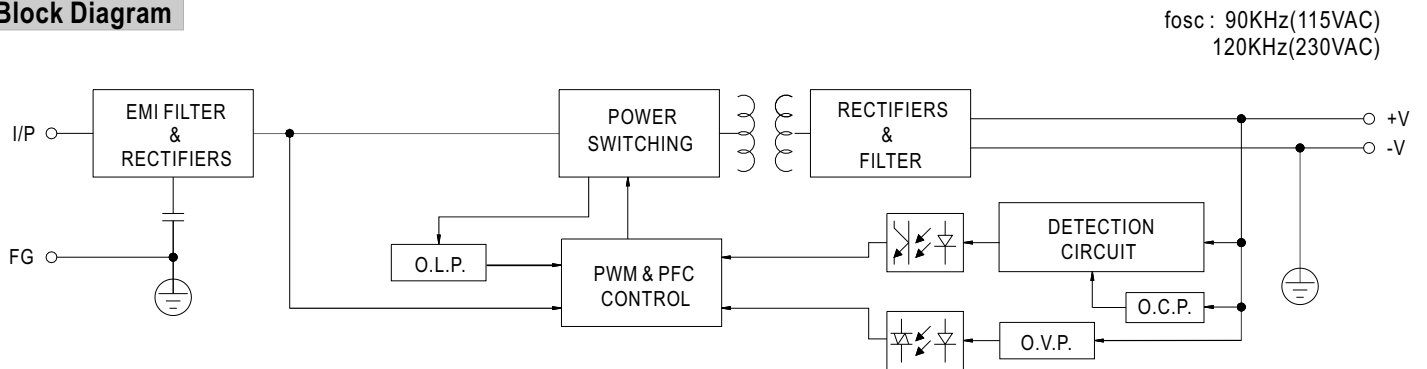

fosc : 90KHz(115VAC)
120KHz(230VAC)

■ Derating Curve

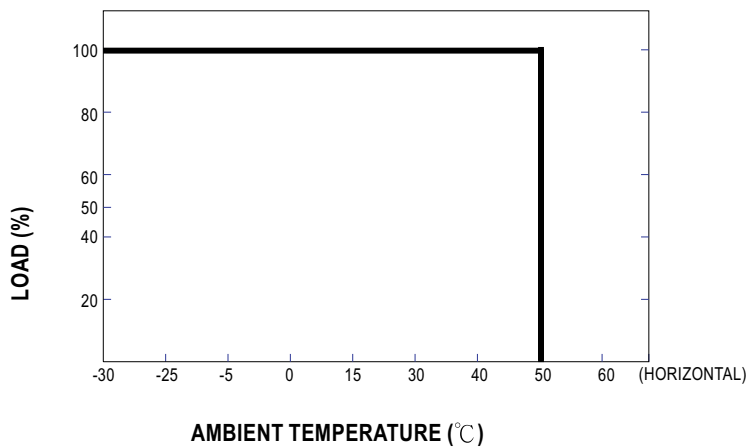

■ Static Characteristics

